

RECYCLING UNIT Operating Manual

NOTE: ENSURE THAT ALL RELEVANT PERSONNEL READ THE POINTS LISTED WITHIN THIS LEAFLET AND THAT A COPY IS GIVEN TO STAFF INVOLVED WITH THE INSTALLATION AND MAINTENANCE OF THIS PRODUCT

We recommend that a risk assessment is undertaken to identify an appropriate location for your waste collection and recycling units. In order to reduce risk, some organisations decide to place the units a **minimum of 5 metres** away from buildings.



IMPORTANT NOTE:

THE BIN MUST BE SITED ON LEVEL GROUND TO ENSURE CORRECT ALIGNMENT OF THE DOOR AND BODY. IF YOU ARE NOT USING GLASDON FIXINGS YOU MUST ENSURE THAT 50MM DIAMETER WASHERS ARE USED IN ORDER TO SECURE THE BIN WHEN GROUND FIXING.



RECYCLING UNIT *FOOD WASTE MODEL*

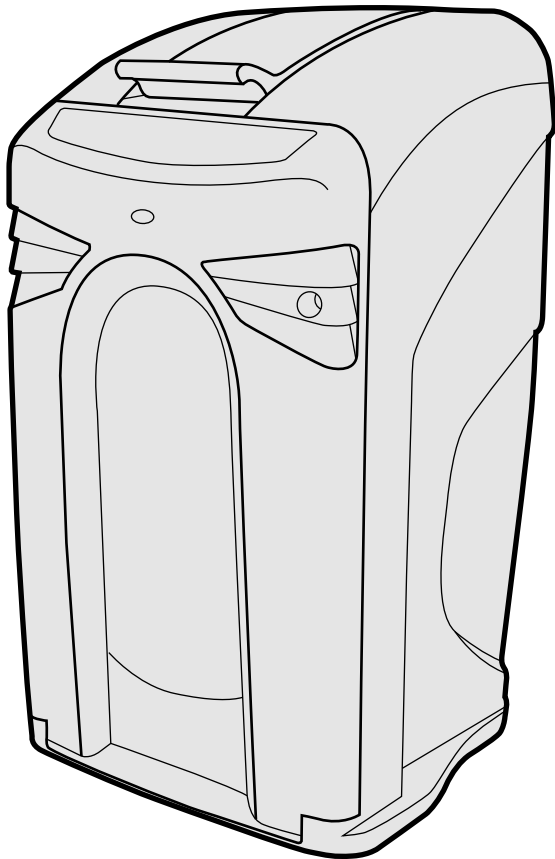

RECYCLING UNIT

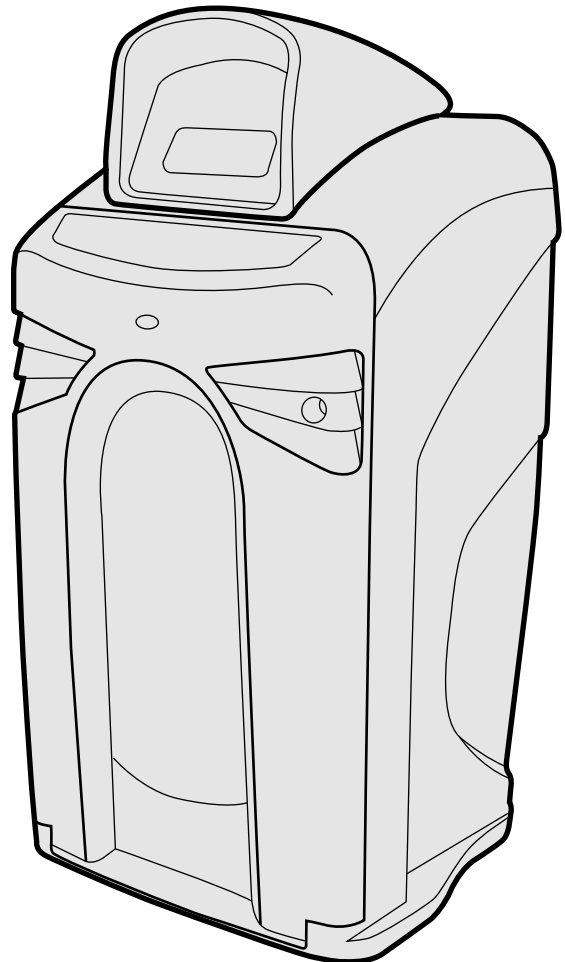

Note: For the purposes of these instructions all illustrations are based on the Food Waste Model.

FOOD WASTE MODEL ONLY

Opening/Closing Aperture Flap to Dispose of Food Waste

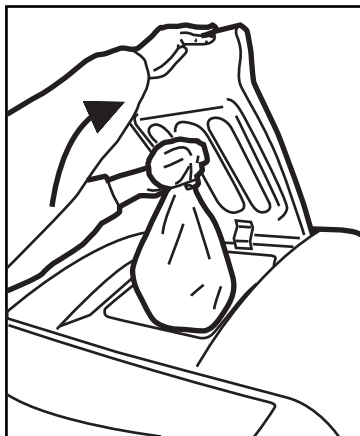

1. Lift the flap upwards until it stops. Note: The flap does not open past 90 degrees.

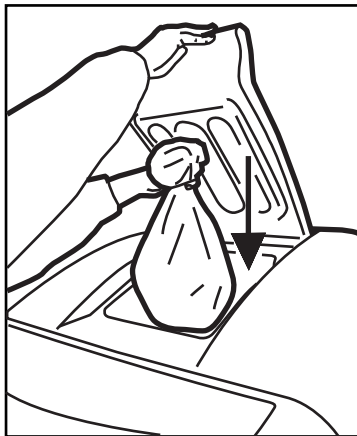

2. Drop sack of food waste through the aperture then let go of the flap. Note: The soft close mechanism will ensure the flap closes.

Opening/Closing Bin

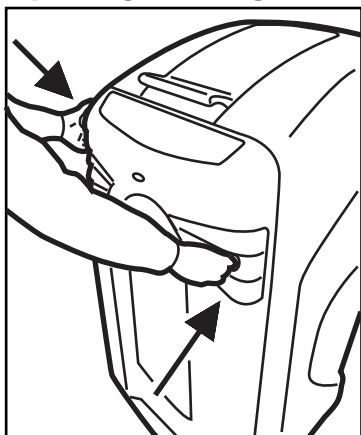

3. Insert key into the key hole and place left hand around the handle detail in line with the door hinge on the left side of the bin.

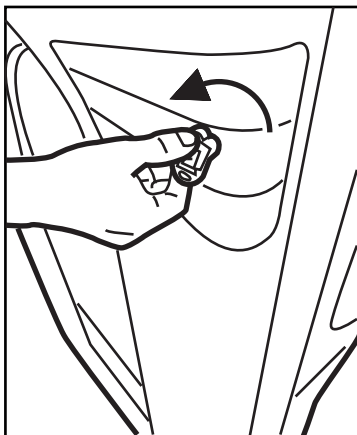

4. Turn key anticlockwise until it stops.

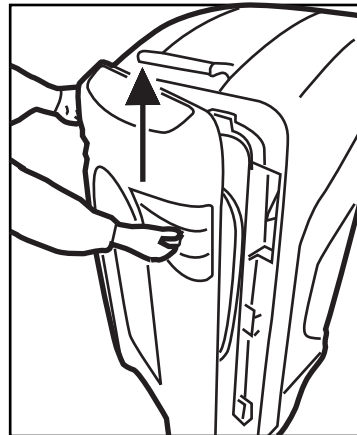

5. Using both hands lift the door and allow the door to pivot open.

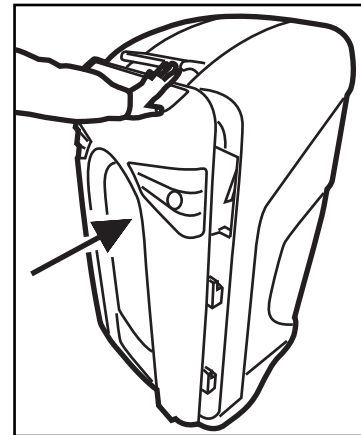

6. Slam the door to shut (no key required to lock)

Inserting Wheelie Bin

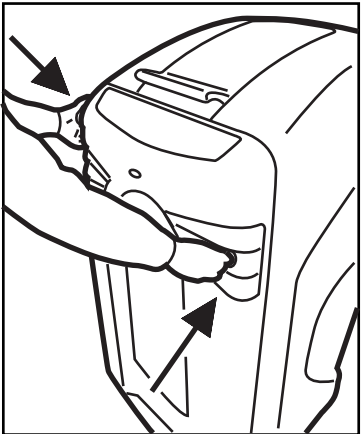

7. Open the door. (See previous details.)

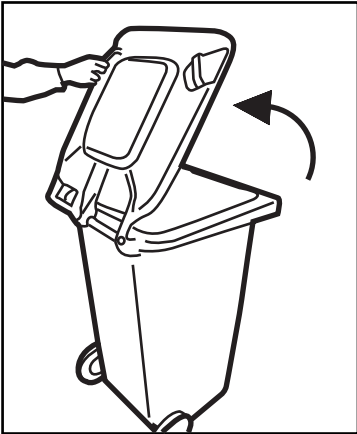

8. Open the lid of the wheelie bin.

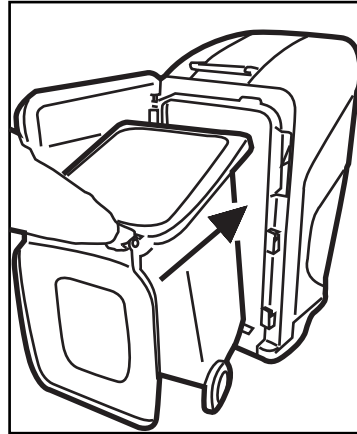

9. Push the wheelie bin into the housing so that the wheels sit in the location points. This will ensure that waste enters the wheeled bin.

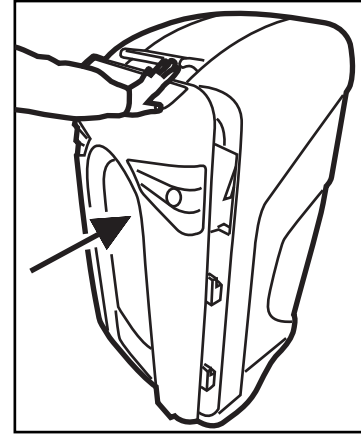

10. Slam door to shut.

Removing Wheelie Bin

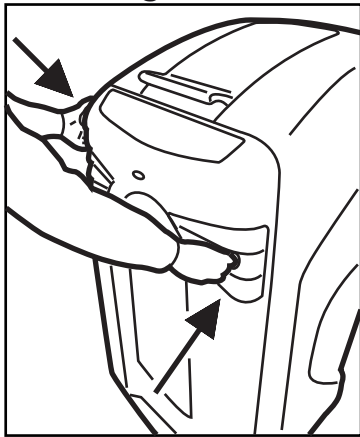

11. Open the door. (See previous details.)

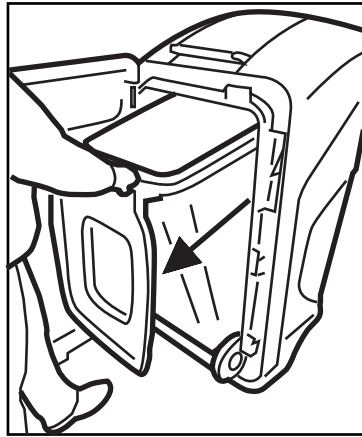

12. Using the handles pull the wheelie bin out of the housing.

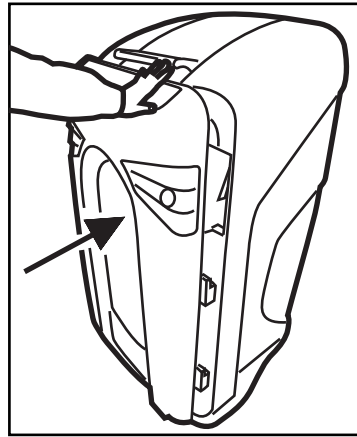

13. Slam door to shut.

Inserting/Removing Poster (Accepts LAMINATED A3 paper/card with a visible viewing area of 350mm x 267mm)

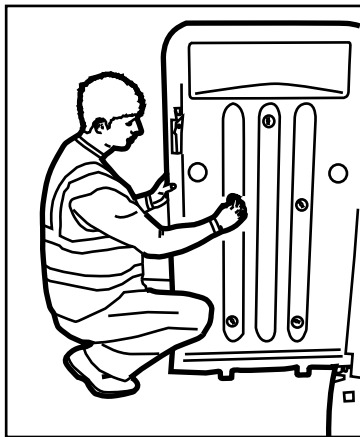

14. Remove all five wingnuts and washers from the inside of the bin by unscrewing anticlockwise.

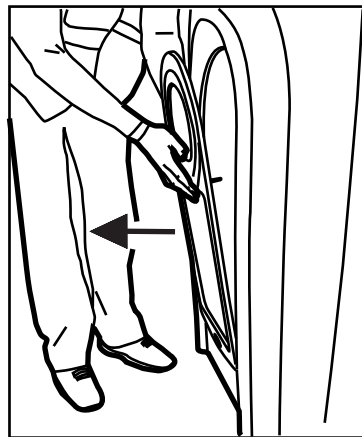

15. From outside of the bin, remove the frame and insert/replace poster behind the clear panel.

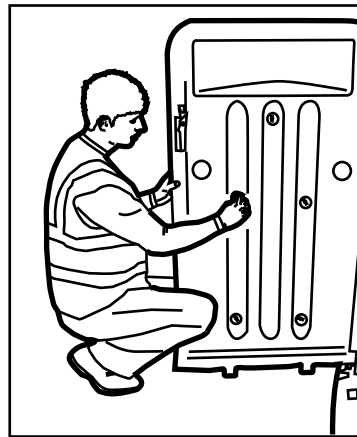

16. Place the frame back into position and tighten wingnuts from the inside of the bin to secure. **IMPORTANT NOTE:** Do not overtighten wingnuts.

Inserting Internal Ballast (Paving Slab - 240 litre model)

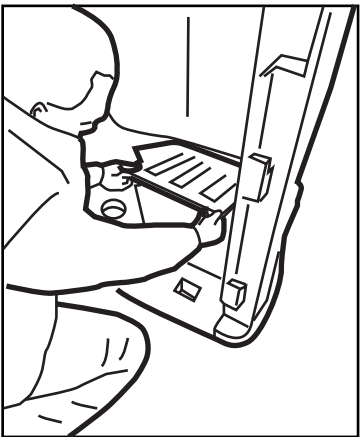

17. From inside of the bin lift up the base plate to access the recess below.

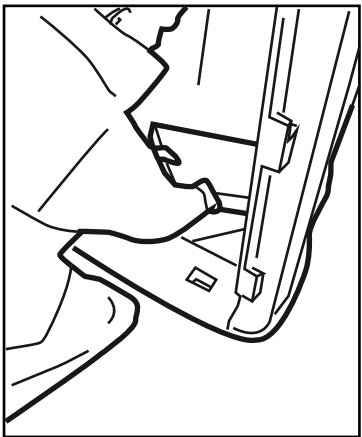

18. Place a 400mm x 400mm x 50mm paving slab into the recess.

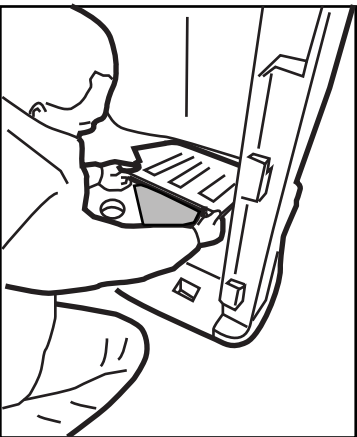

19. Replace the base plate on top of the paving slab.

Note: Both models (140&240) can accept an internal ballast.

Nexus City 240 internal ballast is a paving slab weighing 19kg.

Nexus City 140 has an internal ballast made from concrete weighing 40kg. This option does not have the base plate.

INSTRUCTIONS FOR CONCRETE FIXING KIT (INTO PREPARED CONCRETE FOUNDATION)

IMPORTANT NOTE: TO ENSURE A SECURE AND ROBUST INSTALLATION THE BIN SHOULD BE SITED ONTO A SOUND CONCRETE FOUNDATION AND THE 50MM DIAMETER WASHER MUST BE USED. WE STRONGLY RECOMMEND THAT THE BIN IS **NOT** INSTALLED ONTO TARMAC OR BLOCK PAVED AREAS.

DISTANCE FROM EDGE OF FOUNDATION TO CENTRE OF GROUND BOLT TO BE NO LESS THAN 110MM

Permanently sited onto a prepared concrete ground site (20-30N/mmsq) utilising 4 M10x100mm ground fixing bolts. This fixing kit is an optional extra.

- 1) Position bin onto siting area ensuring it is the correct distance away from the edge of the concrete (minimum 110mm) and is in the correct orientation with regard to the apertures.
- 2) From the inside of the bin mark hole positions onto the concrete through the fixing holes in the base of the bin with a 12mm diameter masonry drill. Remove the bin.
- 3) Using a 12mm diameter masonry drill bit, drill and clean out anchor holes to a minimum depth of 130mm. Position bin back over the drilled holes.
- 4) Assemble the ground bolts as shown in diagram opposite by removing the 20mm washer and replacing it with the 50mm washer. Drive the ground bolts through the holes in the base of the bin and into the holes in the concrete.
- 5) Tighten nut with correct spanner until fixings are secure. Max recommended torque setting - 20lbs/ft (27Nm).
- 6) In the event of the bin being removed, simply remove the bolt to leave the site hazard free.

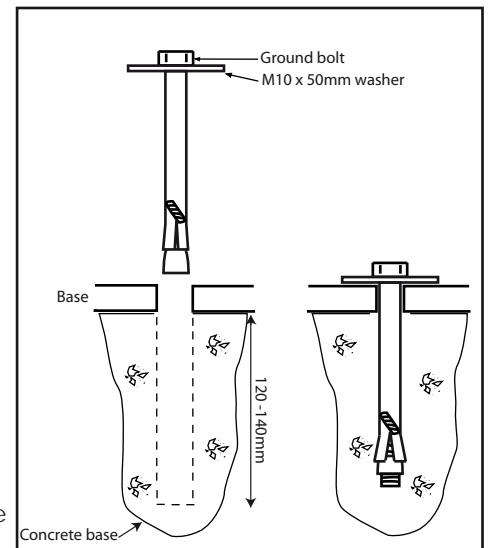

NOTE: For alternative fixing methods please contact us for details.

Cleaning Your Bin

We would recommend a warm pressure wash with soap or alternatively hand wash with 10% solution of mild detergent in warm water using a soft bristle brush followed by a rinse with clean water.

Graffiti

Felt tip pen or paint may be removed from Durapol using a proprietary graffiti remover such as Glasdon GraffitiX. Carefully follow the instructions, particularly the guidelines covering safety. Ensure that all traces of chemicals are removed then clean as detailed above.

CAUTION:

Graffiti removers can damage stickers, some protection may be afforded by masking off such areas. Please refer to Technical Services for our recommended graffiti removal supplier.

Maintenance

A planned maintenance schedule of regular inspection is recommended and components replaced when necessary.

 **Glasdon**, NEXUS[®] CITY 240 RECYCLING BIN AND NEXUS[®] CITY 140 RECYCLING BIN ARE TRADEMARKS OF GLASDON GROUP OR ITS SUBSIDIARIES IN THE U.K. AND OTHER COUNTRIES

- A planned maintenance schedule of regular inspection is recommended, replacing components as necessary.
- Replacement components are available direct from GLASDON UK LIMITED.
- GLASDON UK LIMITED cannot be held responsible for claims arising from incorrect installation, unauthorised modifications or misuse of the product.

Issue 3 November 2015 C000/0454 DWG No. 07B351-36
© Copyright November 2015
Glasdon UK Ltd reserve the right to alter specifications without prior notice.

 **Glasdon**
Glasdon U.K. Limited

Preston New Road
BLACKPOOL
Lancashire FY4 4UL
Tel: 01253 600410
Fax: 01253 792558

email: sales@glasdon-uk.co.uk
web: www.glasdon.com